

Table I. Capacitor Standards Specifications

Nominal Value	Model	Initial Calibration Value <sup>(1)</sup>	Calibration Accuracy (%)	Calibration Conditions <sup>(2)</sup>	Temperature Coefficient (ppm/°C)	Max Voltage (Vp-p)
10 pF	1409A100	10 ± 0.2 pF	±0.05	2Vrms, 1kHz, 23±3 °C, < 65% RH	±30	200
100 pF	1409B101	100 ± 0.5 pF	±0.05	2Vrms, 1kHz, 23±3 °C, < 65% RH	±30	200
1 nF	1409C102	1 ± 0.002 nF	±0.05	2Vrms, 1kHz, 23±3 °C, < 65% RH	±30	100
10 nF	1409D103	10 ± 0.02 nF	±0.05	2Vrms, 1kHz, 23±3 °C, < 65% RH	±30	50
100 nF	1409E104	100 ± 0.2 nF	±0.05	2Vrms, 1kHz, 23±3 °C, < 65% RH	±30	50

- (1) Capacitor Standards have no adjustments and come in fixed, calibrated values close to the nominal value by component selection with tolerance as shown in the table.
- (2) Capacitor standards intended for use with the Model 3000 Capacitance Meter are calibrated using test frequencies: 240 Hz, 2.4 kHz, and 24 kHz.

The capacitor standard and its equivalent circuit are shown in Figure 1 and 2, respectively. The dielectric of all capacitors used in the standards is ceramic, type C0G. Each capacitor standard is housed in a metal case (L=2.0 in x W=1.5 in x H=1.2 in) and has internal thermal isolation to minimize rapid temperature changes during handling. The BNC terminals are on 0.750 inch spacing and are plug compatible with the connector spacing the Model 3000 Capacitance Meter. Each capacitor standard is serialized and bar coded for inventory control.



Figure 1. Capacitor Standard

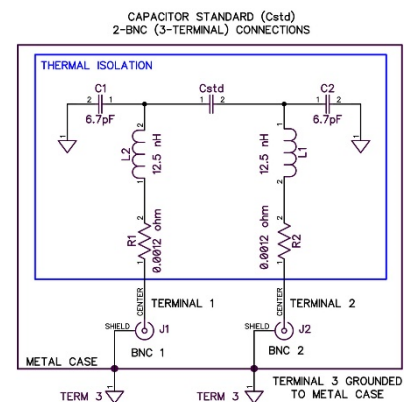

Figure 2. Equivalent Circuit

The capacitor standard (Cstd) is connected between BNC terminals 1 and 2. There is approximately 6.7 pF stray capacitance (C1 and C2) between each center pin of the BNC connectors and case ground. The stray capacitance-to-ground does not contribute to Cstd when making measurements with the Model 3000 Capacitance Meter or capacitance bridges such as IET-GenRad 1620 or 1621. The approximate internal residual resistance (R1, R2 = 0.0016 ohm) and lead inductance (L1, L2 = 12.5 nH) contribute negligible impedance for test frequencies below 100 kHz.